



# SJIII 4626/32

## ELECTRIC SCISSOR LIFTS

### STANDARD FEATURES

- DC motor controller
- Drivable at full height
- Variable speed, rear two wheel hydraulic drive
- Dual holding brakes
- Proportional controls for drive & lift functions
- 4' (1.22 m) Roll out extension deck
- 24V DC power source
- Low voltage battery protection
- Up to 30% gradeability
- Solid rubber, non-marking tires
- Pothole protection system
- 110V AC outlet on platform with GFI
- 28 mph wind rating (12.5 m/s)
- Tilt alarm with drive & lift cut-out
- All motion audible alarm
- Lanyard attachment points
- Operator horn
- Hinged railing system
- Forklift pockets and tie down/lift lugs
- Relay based control system
- SKYCODED™ color coded and numbered wiring system
- Telematics ready

### ACCESSORIES AND OPTIONS

- Flashing light
- Dual flashing lights
- Extended control box cable
- Light duty pipe rack
- Heavy duty pipe rack
- Tool caddy
- Drywall/board carrier (SJIII 4632)
- 6' (1.8 m) Powered ext. deck (SJIII 4626)\*  
\*adds 280 lbs to unit weight and capacity remains the same
- 800W AC inverter
- 250 Ah batteries (cannot be combined with EE rating package)
- AGM Batteries
- EE rating package
- Aircraft protection package (SJIII 4626)  
(Includes full height gate, 6' power deck, bumper padding, bumper rails, morton tread plate, modified air-line to platform, spin-off hydraulic filter, extension deck interlock, front access gate with interlock, filter fittings on power deck ext. hydraulic circuit, base powerdeck controls (incl. keyless start/base toggle switches), entry handrails, safety labels, interlock on rear entrance, e-coating on deck only, napa ground strap manuals (1 operator, 1 parts, 1 service, 1 usb per machine), 35 mph wind rating, off-board battery charger)
- Half height spring hinged gate
- Full height spring hinged gate
- Bio oil
- Non destructive testing
- ELEVATE telematics package
- Warranty Options (3 year or 5 year plans available)
- Secondary Guarding Lift Enable (SGLE) w/ shroud

† Standard lead times may be increased when optional equipment is added, consult factory.

‡ Capacities, and machine weights may differ when options are added.

# SJIII 4626/32 ELECTRIC SCISSOR LIFTS

Dimensions	SJIII 4626	SJIII 4632
<b>A</b> Work Height	32' (9.75 m)	38' (11.58 m)
<b>B</b> Raised Platform Height	26' (7.92 m)	32' (9.75 m)
<b>C</b> Lowered Platform Height	45" (1.14 m)	48.5" (1.23 m)
<b>D</b> Overall Width	46" (1.17 m)	46" (1.17 m)
<b>E</b> Overall Length	91" (2.31 m)	91" (2.31 m)
<b>F</b> Stowed Height (Rails Up)	84.5" (2.15 m)	88" (2.24 m)
<b>G</b> Stowed Height (Rails Down)	70.5" (1.79 m)	74" (1.88 m)
<b>H</b> Platform Width (Inside Dimension)	42" (1.07 m)	42" (1.07 m)
<b>I</b> Platform Length (Inside Dimension)	84" (2.13 m)	84" (2.13 m)
Specifications	SJIII 4626	SJIII 4632
Extension Deck (Roll Out)	4' (1.22 m)	4' (1.22 m)
Ground Clearance (Stowed)	3.5" (8.89 cm)	3.5" (8.89 cm)
Ground Clearance (Raised)	0.75" (1.91 cm)	0.75" (1.91 cm)
Wheelbase	69" (1.75 m)	69" (1.75 m)
Weight	4,700 lbs (2,132 kg)	5,075 lbs (2,302 kg)
Gradeability	30%	25%
Turning Radius (Inside)	47.5" (1.21 m)	47.5" (1.21 m)
Turning Radius (Outside)	93.5" (2.37 m)	93.5" (2.37 m)
Lift Time (With Rated Load)	54 sec	59 sec
Lower time (With Rated Load)	32 sec	49 sec
Drive Speed (Stowed)	2 mph (3.2 km/h)	2 mph (3.2 km/h)
Drive Speed (Raised)	0.6 mph (1 km/h)	0.6 mph (1 km/h)
Maximum Drive Height	Full Height	Full Height
Capacity (Overall)	1,000 lbs (454 kg)	700 lbs (318 kg)
Distributed Capacity (Main Platform)	700 lbs (318 kg)	450 lbs (204 kg)
Distributed Capacity (Extension Deck)	300 lbs (136 kg)	250 lbs (113 kg)
Local Floor Load (With Rated Load)	235 psi (1620 kPa)	220 psi (1517 kPa)
Overall Floor Load (With Rated Load)	191 psf (9 kPa)	204 psf (10 kPa)
Maximum # of Persons	3	2
Wind Rating	28 mph (12.5 m/s)	28 mph (12.5 m/s)
Tire Type	Solid, N/M	Solid, N/M
Tire Size	16 x 5 x 12	16 x 5 x 12

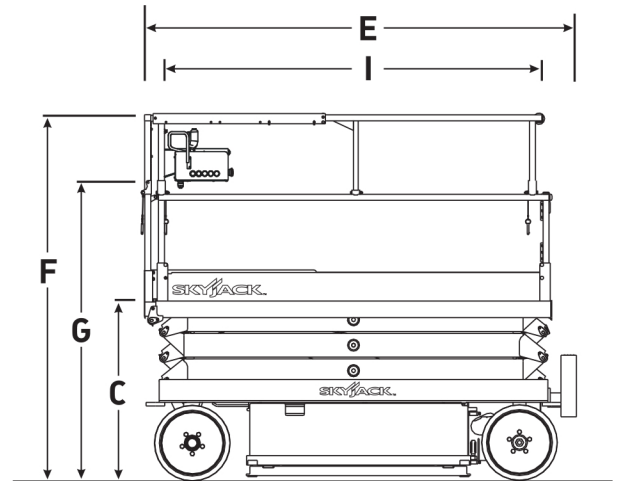
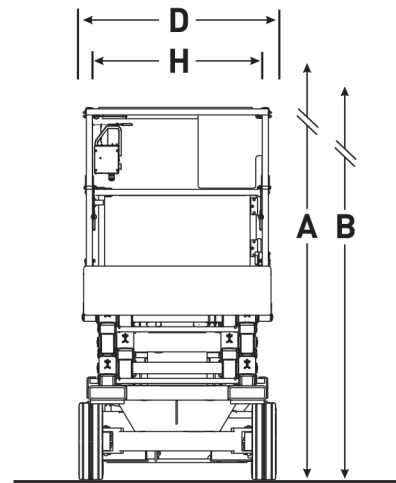

PARAMOUNT PLATFORMS LTD  
 GRANITES CHASE, BILLERICAY, ESSEX, CM11 2UQ  
 01268 517717  
 HIRESK@PARAMOUNTPLATFORMS.COM

This brochure is for illustrative purpose only and based on the latest information at the time of printing. Skyjack Inc. reserves the right to make changes at any time, without notice, to specifications, standard and optional equipment. Consult the Operating Maintenance and Parts Manuals for proper procedures. Work platforms have been tested to comply with ANSI and CSA standards as interpreted by Skyjack Inc.

